

NON-INSULATED TRAY DELIVERY CART MODEL 101-1520 SERIES

FEATURES AND BENEFITS:

- Non-insulated cabinet for tray transport and storage. Ideal for use as a patient tray delivery cart.
- Same size top and base extend past sidewalls to act as natural bumpers for protection. Extruded frame fully welded.
- Body constructed of non-corrosive, Hi-Tensile aluminum for strength and ease of mobility.
- Optional pass-thru design for easy access from either side.
- Reinforced, full length door swings 270° and can be latched to the cabinet side for convenience. Card clip included.
- Gravity type latch secures door during transport.
- Extruded angle ledge pan supports hold
- 15" x 20" trays on 5-1/2" centers.
- Interior pan stops on door and back allow proper air flow.
- Heavy duty 5" swivel casters, two with brakes. Provides mobility when fully loaded.



101-1520-10



ACCESSORIES and OPTIONS

(Available at extra cost):

- Pass-Thru
- Lock Hasp
- Various Caster Options
- Corner Bumpers
- Perimeter Bumper
- Floor Lock (for use with 5" casters)
- Plexiglass Door
- Push Handle (rear)
- Bail Handle Kit
- Left-Hand Hinged Door

See page A-20 for accessory details.

101-1520 SERIES

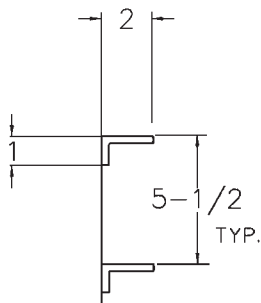

DETAIL OF
PAN SLIDE

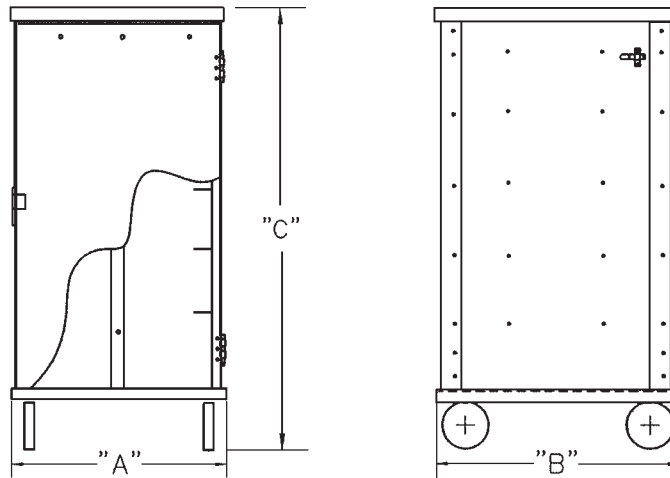

CRES COR MODEL NO.	PAN			DIM "A"	DIM "B"	DIM "C"	INSIDE DIMENSIONS			WEIGHT ACT.	
	CAP	SIZE		WIDTH	DEPTH	HEIGHT	WIDTH	DEPTH	HEIGHT		
101-1520-10	10	15 x 20	IN	23-3/4	33-1/2	35-3/4	20-15/16	31	27-1/2	LBS	96
		385 x 510	MM	605	855	910	535	790	700	KG	44
101-1520-12	12	15 x 20	IN	23-3/4	33-1/2	42	20-15/16	31	33-3/4	LBS	116
		385 x 510	MM	605	855	1070	535	790	860	KG	53
101-1520-20	20	15 x 20	IN	23-3/4	33-1/2	63-3/4	20-15/16	31	55-1/2	LBS	126
		385 X 510	MM	605	855	1620	535	31	1410	KG	57

When ordering bumpers, add 2" to overall dimensions.

ALL CONSTRUCTION IS RIVETED, WELDED AND FINISHED.

CABINET:

- Top: One piece .063 aluminum.
- Posts: Extruded aluminum channels, 7/8 x 2-1/4 x .102, welded to top and base, form a solid frame.
- Sides and back: .063 panels riveted to posts.
- Back panel: Fitted into posts, riveted to top and reinforced.
- Tie rod: Applied at front of 101-1520-20.
- Pan stop channels: Riveted to inside rear of cabinet and door.

BASE:

- One piece construction, .125 aluminum.
- Casters: 5" dia., swivel, modulus tires, 1-1/4" wide, load cap. 250 lbs. each, temp. range -45°/+180°F. Delrin bearings. Front casters equipped with brakes.

DOOR:

- Panel: Formed .063 aluminum.
- Reinforcement: 3/8 x 1-1/2 extruded bars riveted and welded horizontally to top, center and bottom.
- Latch: Gravity type, nickel plated steel.
- Swings 270° on butt hinges, riveted to posts and door panel.
- Slide latch holds door open.

PAN SLIDES:

- Angles: Extruded angle supports 1 x 2 x .125 riveted to sides on 5-1/2" centers.

SHORT FORM SPECIFICATIONS

Cres Cor Utility Tray Delivery Cart Model 101-1520-_____.
Formed and welded .063 aluminum top, .125 aluminum base. Extruded aluminum angles riveted on 5-1/2" centers. Holds (____) 15" x 20" trays. Formed .063 aluminum door. 5" swivel modulus casters, Delrin bearings. Load capacity 250 lbs. each. Provide the following accessories: _____
_____. NSF listed. 2 year parts warranty.



5925 Heisley Road • Mentor, OH 44060-1833
Phone: 877/CRESCOR • Fax: 440/350-7267
www.crescor.com

© Crescent Metal Products, Inc. 2013 All rights reserved.

In line with its policy to continually improve its products, CRES COR reserves the right to change materials and specifications without notice.

Litho in U.S.A.